

## TABLE OF CONTENTS

<b>S.No</b>	<b>Contents</b>	<b>Page No.</b>
1.	Basic Textile terms	1
2.	Various types of fabric	1
3.	Some of the common Fabrics Used in Garment Industry as below	4
4.	Sequence of Operations In Garment production	8
5.	Fabric defects	9
6.	Requirements for visual inspection	24
7.	Checking of dimensions	25
8.	Inspection	27
9.	Types of inspection systems	27

## 1. Basic Textiles terms

Yarn	Basic raw material for weaving/Knitting
Type of yarn	Single ply, double ply and multiply
Yarn count	Defines thickness of yarn. Higher the count, finer the yarn
Warp	Lengthwise yarn in the fabric.
Weft (filling)	Width wise yarn in the fabric.
Selvedge	Edges of the fabric running lengthwise
Woven Fabric	Woven fabrics are made by using two or more sets of yarn interlaced at right angles to each other.
Knitted Fabric	Knitted fabrics are formed by series of interlocking loops (example: knit wears)
Sewing Thread	Sewing Thread is a type of yarn used for sewing.

## 2. Various types of fabric

**Fabrics:-** Sets of yarns are used for formation of fabric, Fabrics are produced in number of ways which are detailed below:

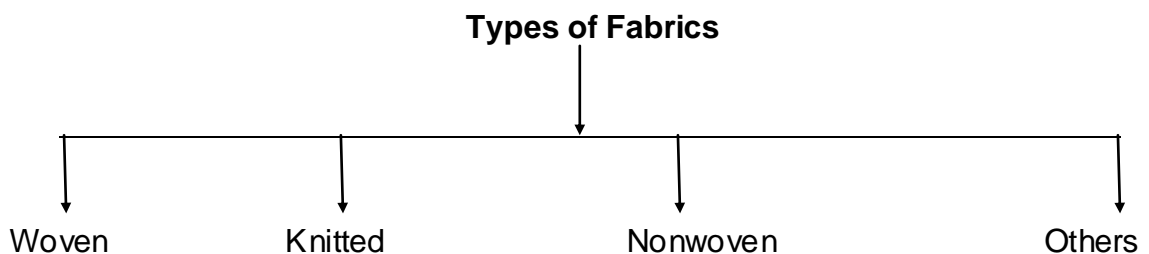

- Woven Fabric: A woven fabric is composed of two basic series of yarn called warp and weft
- Knitted Fabric: Fabric which are constructed by interlocking a series of loop of one or more yarns by hand or by machine are called knitted Fabrics.

- Non Woven Fabric: It is produced by mixing fibers and making into the form of a thick layer of web of width corresponding to desired width of the fabric.
- Other Fabrics: Braids, Lace, Netting, Felt etc

**Parts of Woven fabrics:**

**Body:** It is the main portion of the fabric containing the intended fabric design.

**Selvedge:** It is the narrow woven edge portion of the fabric parallel to the warp, made with special strong yarns in a closer construction than the body to prevent unraveling.

**Face:** It is the intended front side of the fabric.

**Back:** It is the intended back side of the fabric.

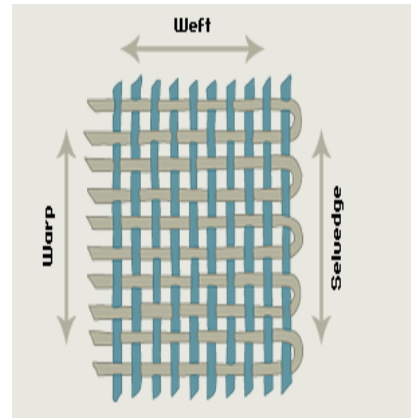

**Two base knitted fabric structures**

**Weft Knitting:**

In Weft knitting loops are made in a horizontal way from single yarn. Intermeshing of loops takes place on a course-wise. Type of weft knits are Plain Jersey Knit, Purl Knit, Rib Knit, Patterned Knits & Double Knits.



**Warp Knitting:**

In warp knitting loops are made in a vertical way along the length of the fabric from each warp yarn. Intermeshing of loops takes place on a wale-wise. Type of warp knits are Tri-cot, Rachel knits.



## Lace Fabric

Lace is an ornamental or decorative openwork fabric in which design elements formed by the inter twisting of threads joined either by meshes, usually of regular size & shape, forming an apparent openwork fabric.



## Net fabric

It consists of warp threads with weft threads which twist around each warp thread & run diagonally from selvedge to selvedge. Net fabrics have three series of threads parallel warp threads, mesh threads & binding threads.

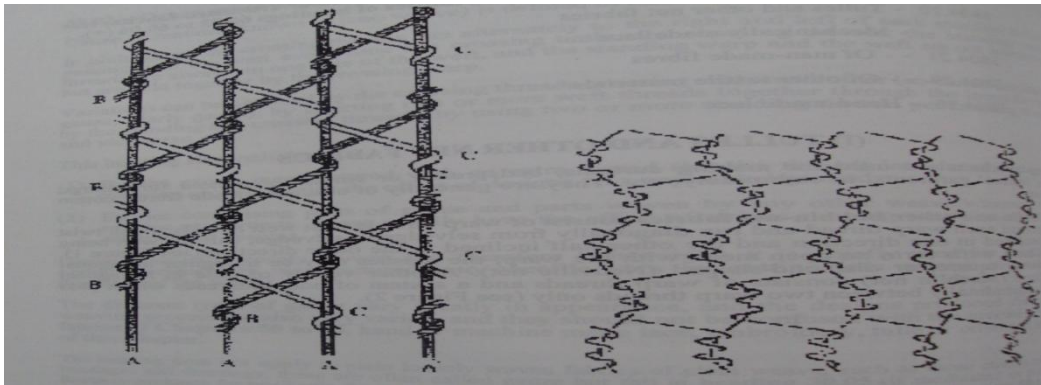

## Categorization of the fabric based on Processing:

Grey Fabric

Bleached Fabrics

Dyed Fabrics

Yarn Dyed Fabrics

Tie and Dye Fabrics

Printed Fabrics

Printed warp Fabrics

## Categorization of the fabric based on Pattern:

Plain Fabric

Stripes Fabric

Checks Fabric

Figured- Dobby & jacquard Fabric

Embroidered Fabric

### 3. Some of the common Fabrics Used in Garment Industry as below:

- **Batiste** originally was woven of cotton or linen and was sheer. It may be used for blouses dresses and lingerie.
- **Canvas** is strong plain-woven cotton used as a home decorating fabric.
- **Chenille** is a fur-like textured fabric made of cotton, silk, rayon, or wool. The warp threads are woven in groups. The fabric may be used as upholstery and clothing.
- **Corduroy** may be derived from the French word Corduroy 'cordeuroi', "cloth of the king". Corduroy is made of durable cotton or rayon velvet and has wide or narrow wales, cords, or ribs. First used as work clothes but now popular as casual dress.
- **Denim** is a twill weave cotton fabric. It may also Denim be cotton blended with rayon, polyester, or spandex. First worn as work wear, denim is popular as dresses, skirts, jackets, and trousers.
- **Eyelet** fabrics have small cut outs with stitching at Eyelet around the edges of the cut. The fabric is used most often in children's wear.
- **Flannel** is generally 100% cotton but may also be made Flannel of wool. It may be a twill or plain weave. The face is brushed to create a soft, plush nap. It is often used for underwear, jackets, dresses, skirts, trousers, and pajamas.
- **Flannelette** is soft cotton that is napped on one side Flannelette . It is used to make underwear, nightwear, and children's clothing.
- **Guatemalan Cotton** is 100% cotton woven in Guatemala Guatemalan Cotton n ethnic designs. The fabric is used to make skirts, vests, jackets, tops, and home decorative items.
- **Jersey** is a soft, stretchy knitted fabric of cotton , nylon, rayon, wool, or other synthetic fibers. It was first used on the Channel Island of Jersey in the late 19th century as sportswear.
- **Piqué** is medium-weight cotton with a raised weave resembling a check.
- **Shirting** is made from long staple cotton and is use Shirting d to make tailored shirts, pajamas and boxer shorts.

- **Terrycloth** is also called toweling. The cotton is Terrycloth woven with uncut loops on one side. It is typically used for towels but may also be used for beach wear or robes.
- **Voile** is a fine, sheer plain weave fabric made of Voile cotton, silk, wool or manufactured fibers. It is used to make blouses and dresses.

#### **Types of nylon fabrics and their uses:**

- The most common use is in carpets. • Nylon is frequently used to make lingerie, hosiery, socks, and sportswear.
- Tulle was originally made of silk and may have originated in Toul France. It is a fine fabric of hexagonal mesh. Tulle is often used dress and hat trimmings as well as bridal gowns.

#### **Types of polyester fabrics and their uses:**

- **Eyelash** is lightweight polyester knit with a hairy face. It is used for sweaters, stoles, and scarves.
- **Faux Fur** comes in two weights: a silky low-pile ray Faux Fur on or polyester, and stiffer, long-pile polyester. The fabric may be used to make capes or craft items.
- **Polyester Silky** Polyester Silky Polyester Silky is as the name describes. It is suitable for blouses, dresses, and nightwear.

#### **Types of rayon fabrics and their uses:**

- **Gabardine** is a registered trade name and Gabardine is a twill weave fabric made of rayon, cotton, or silk. It has been used in suits, coats, dresses, and pants.
- **Rayon Viscose** is produced from wood pulp and is the Rayon Viscose most common type of rayon made. This fabric is used to make full pants, full or A-line skirts, and dresses.
- **Sueded Rayon** is brushed and has a silk-like hand. Sueded Rayon It is used to make full pants, skirts, and shorts as well as unstructured tops.

- **Silk** is made from the cocoon of the silk worm. Types of silk fabrics and their uses are
- **Brocade** is a figured silk fabric with gold or silver Brocade r woven into it to create a raised design. It is often used in evening wear.
- **Charmeuse** is the trade name of a 20<sup>th</sup> century satin weave fabric of silk, cotton, polyester, or rayon. It may be used for blouses, pants, lingerie or piping.
- **Chiffon** is made of silk, rayon, or polyester. Silk Chiffon has the best drape and is used to make full pants, loose tops, and flowing dresses.
- **China Silk** is a plain weave silk. It is light weight China Silk and suitable for garment linings.
- **Damask** is a durable, lustrous, reversible figured fabric. It is commonly used to make tablecloths and napkins.
- **Georgette** is silk or rayon similar to chiffon. It Georgette is used in eveningwear.
- **Pongee** is a soft, thin Chinese or Indian silk and is generally a natural light brown color.
- **Satin** is made of silk, polyester, or rayon. It is Satin used for evening or special-occasion wear.
- **Silk Dupion** is thick, crisp, and nubby (irregular). Silk Dupion is suitable for tailored pants, jackets, fitted dresses, straight skirts, or vests.
- **Silk Gazar** is a crisp medium weight silk suitable for blouses and loose evening coats. The fabric has a “gauzy” appearance.
- **Silk Noil** is also referred to as raw silk. It is made of short waste fibers and is affordable. The fabric has a dull finish and ravel, but readily accepts dye. Silk Noil is used for unstructured clothing such as full pants and skirts, loose dresses, and big shirts.
- **Silk Organza** Silk Organza may also be made of rayon and polyester, but organza made of silk is preferred for its superior handling. Silk organza is stiff, plain, thin and nearly transparent. Lightweight organza is used for interfacing and underling of silk garments. Heavyweight silk organza may be used as a blouse. As with silk gazar, silk organza is best not used for garments requiring drape.
- **Silk, Sand washed** is brushed which softens the Silk. Sand washed makes it more wrinkle resistant. This fabric is suitable for blouses, full pants, lingerie, and piping.
- **Silk Shantung** is made from the silk wild silkworms. Silk Shantung The fabric has a nubby (irregular) filling creating an uneven effect. It is a crisp fabric that has sheen. The fabric may be used for tailored pants and jackets, fitted dresses, straight skirts, or full special-occasion dresses.

- **Silk, Thai** is similar to silk dupion, but is finer Silk, Thai and less bulky. Thai silk is often used in evening, bridal, and period costuming. It may also be used as a home decorating fabric
- **Silk Tussah** is made from the cocoons of wild or semi-cultivated silkworms. The resulting fibers are course and uneven and when woven create a nubby appearance. The fabric is suitable for tailored pants, jackets and skirts as well as vests and other structured garments. Silk Tussah should not be used in garments that are meant to drape.
- **Silk Tweed** Silk Tweed is suitable for jackets and vests. This fabric snags easily.
- **Taffeta** may be made of real silk or artificial silk Taffeta. This fabric may have been named for the Persian fabric “tartan”. It has a glossy, iridescent sheen and rustles with movement. Taffeta is commonly used in special occasion dresses.
- **Velvet** was originally made from silk. The fabric is often used in evening or special-occasional clothing.

## Wool

Wool is one of the oldest fabrics in the Invented world. Wool is made from the hair of sheep, goats made of camels, and rabbits. Types of wool fabrics and their uses are

- **Alpaca** cloth Alpaca was first introduced in 1836 by Sir Titus Salt as a silk and alpaca blend. In the late 19th century alpaca was blended with cotton. Today alpaca is available as a woven or knit and is commonly used for outerwear.
- **Angora** is made from the hair of the Angora rabbit. Angora It does not take dye well and is generally blended with another type of wool. Angora is used to make sweaters.
- **Boiled Wool** is knitted wool that is felted, that is Boiled Wool the knitted wool is machine-washed in hot water and machine dried, usually more than once. Boiled wool may be used for jackets, cardigans, and mittens.
- **Camel Hair** is made from the under hair of the camel. Camel Hair In the 19th century camel hair was a blend on cashmere and camel. Camel hair is primarily used for outer garment.
- **Cashmere** is made of the hair of the Kashmir goat found in Asia. In the present day, cashmere is used for coats, dresses, scarves, and sweaters. Cashmere may be blended with other fibers.
- **Lamb’s Wool** Lamb’s Wool comes from animals younger than 7 months old. It is a fine soft fabric.



- **Mohair** is made from the hair of the Angora goat. Mohair is loosely woven with cotton, silk, or wool and produces a fuzzy texture. It is used for jackets, coats, skirts, and sweaters.
- **Wool Bouclé** is a loosely woven or knitted fabric with small curls or loops on the face. Bouclé is from the French word boucler, meaning “to curl”. This fabric is used to make sweaters and coats.
- **Wool Challis** is lightweight plain weave wool. It traditionally is printed with a floral pattern and is used for shirts and dresses.
- **Wool Crepe** is the most common crepe, a woven fabric Wool Crepe with a crinkled texture. Wool crepe is ideal for tailored pants, skirts, jackets, or dresses.
- **Wool Gauze** Wool Gauze Wool Gauze is sheer and the least stable wool fabric. It is used to create loose tops, dresses and skirts.
- **Wool Jersey** is a knitted fabric originating from the Wool Jersey e Channel Island of Jersey. It drapes well and is good for wrap and full tops, dresses, full pants and skirts.

#### 4. Sequence of Operations in Garment production

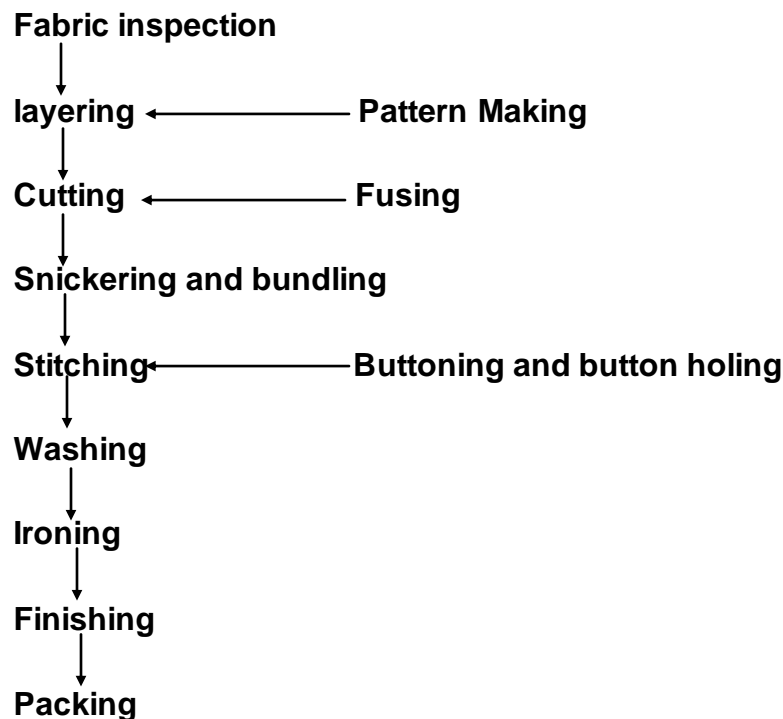

## 5. Fabric Defects

- Yarn Defects

### 1. Broken Filaments

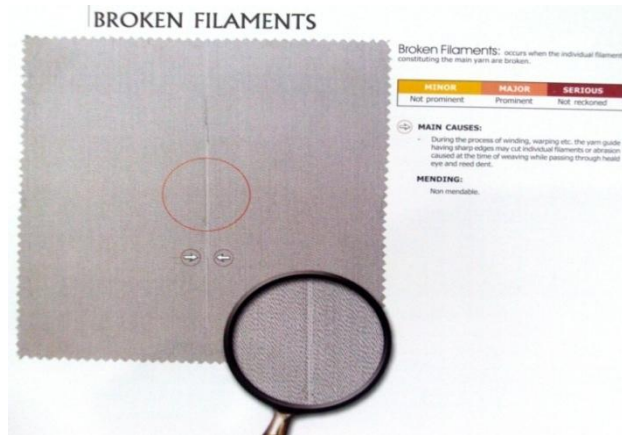

### 2. Colored Flecks

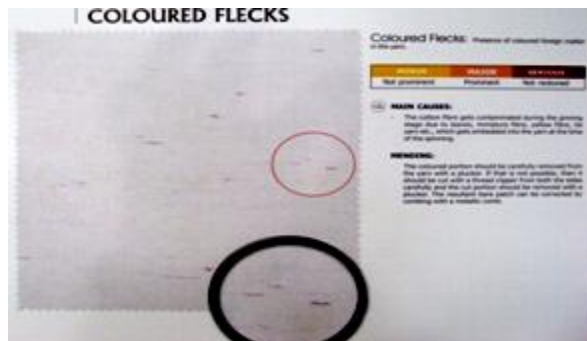

### 3. Slub

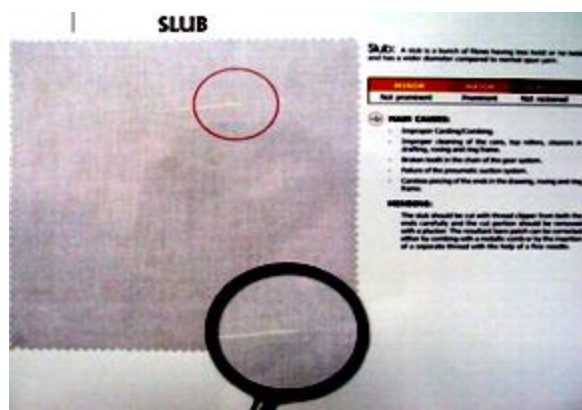

## 4. Slubby Weft



## • Weaving Defects

### 1. Broken Ends Woven in Bunch

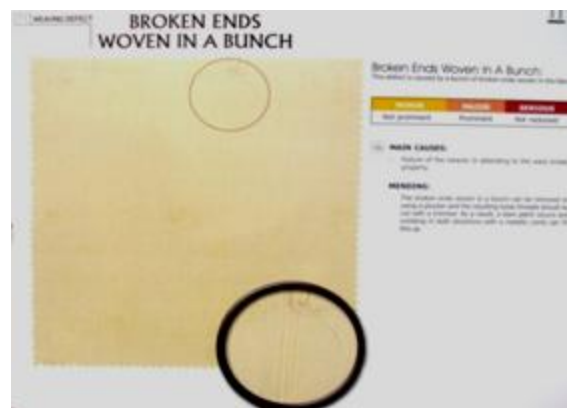

### 2. Broken Pattern



### 3. Double End



### 4. Float



### 5. Gout



### 1. Local Distortion



## 2. Hole,Cut or Tear



## 3. Lashing-in



## 4. Oil or Solid ends

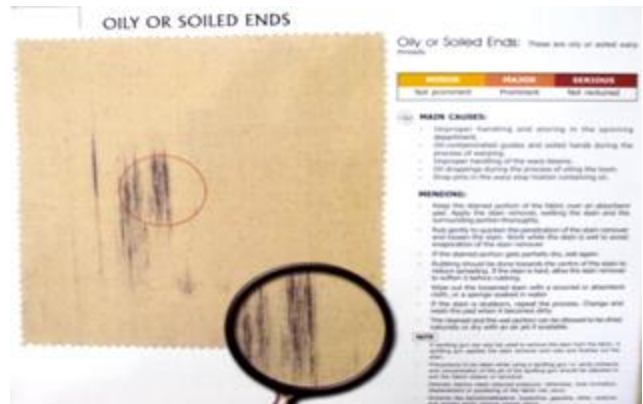

## 5. Missing Ends



## 6. Oily or Other Stain



## 7. Selvage Defect



## 8. Oily Weft

## 9. Reed Marks



# SNARLS

## 10. Snarls

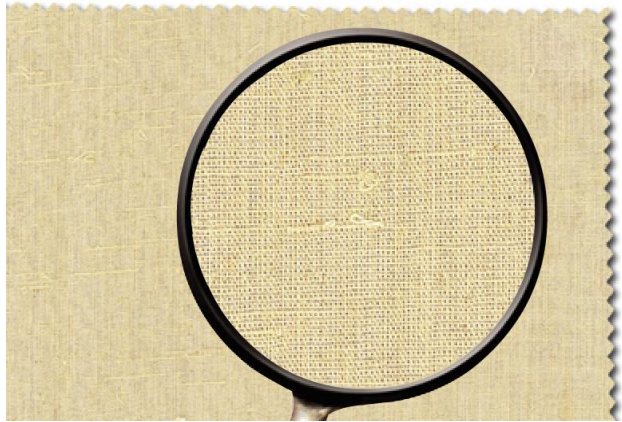

## 11. Slough Off



# SMASH

## 12. Smash



### 13. Weft bar



**Weft bar** : An unwanted bar, running across the full width of a piece which differs in appearance from the adjacent normal fabric.

MINOR	MAJOR	SERIOUS
Not prominent	(a) Prominent upto 5 cms (b) Incase of cramming upto 2 cms	(a) Prominent > 5 cms (b) In case of cramming > 2 cms

**MAIN CAUSES:**  
 - Difference in fibre composition, count/denier, twist, colours, shade, and luster or pick spacing of weft yarn.  
 - Faulty let-off and take-up motion.  
 - Fall of the cloth not being adjusted after loom stoppage for mending.

**MENDING:**  
 Non-mendable.

### 14. Stitches

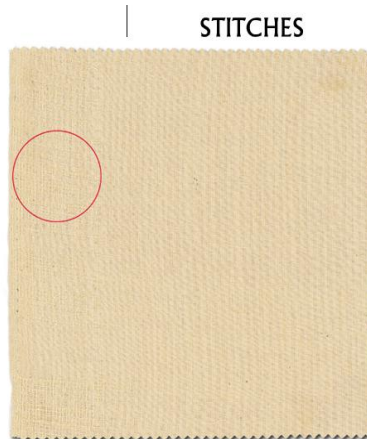

**Stitches** : A single thread float either in the warp or weft way. It is very prominent in case of different colours of the warp and weft.

MINOR	MAJOR	SERIOUS
Not prominent	Prominent upto 15 cms	Prominent more than 15 cms

**MAIN CAUSES:**  
 - Improper local shedding.  
 - Two adjacent ends sticking together during shedding for a brief period of time.  
 - In case of synthetic yarn, ends sticking together due to static charge during weaving.

**MENDING:**  
 - More number of stitches are not mendable. Only a few stitches may be cut with a clipper from both the ends.  
 - Combing in both the directions with the help of a metallic comb may rectify the resultant bare patch formed.

### 15. Untrimmed Loose Threads



**Untrimmed loose threads** : Any hanging threads on the face of the fabrics are termed as loose threads.

MINOR	MAJOR	SERIOUS
Prominent	Not reckoned	Not reckoned

**MAIN CAUSES:**  
 - Tail ends not trimmed after piecing up.  
 - In case of auto loom weft cutters worn out or not properly set.  
 - Carelessness of the weaver while changing the pirn.

**MENDING:**  
 These defects can be easily rectified with the help of a clipper.

### 16. Broken pattern





## 17. Weft crack

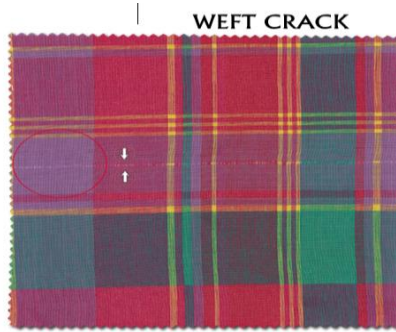

WEFT CRACK

**Weft crack** : A narrow streak running parallel with weft threads caused due to absence of weft.

MINOR	MAJOR	SERIOUS
< 2 pick missing	2 or more full pick missing	missing picks > 0.5 cm along the length

**MAIN CAUSES:**

- Faulty let-off and take-up motion.
- Faulty weft-stop motion.
- Loom break not functioning effectively.
- Anti-crack motion not set properly.
- Fell of the cloth not being adjusted after loom stoppage for mending.

**MENDING:**

Cracks of more than two picks are not mendable. Combing in both the directions with the help of a metallic comb can rectify cracks of one or two picks, which can cover the narrow bare streak. Care should be taken to avoid major local distortion.

## • Piling or Raising Defects

### 1. Knots



### 2. Bleaching Spot



### 3. Pile less spot



- Processing Defects

### 1. Uneven or loose piles



Defects caused by hanging threads: A break in the pattern of the printed fabric caused by hanging threads.

MINOR	MAJOR	SERIOUS
Not prominent	Prominent	Not reckoned

**MAIN CAUSES:**  
Loose threads in the fabric not trimmed before printing.

**MENDING:**  
Non - mendable.

### 2. Hanging threads

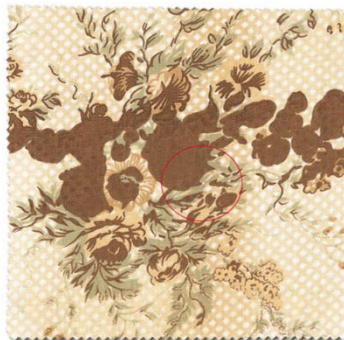

Blurred or dark patch: An unwanted blotch or bar in a printed/dyed fabric results in a blurred patch.

MINOR	MAJOR	SERIOUS
Upto 1 sq. cm.	> 1 sq. cm. to 6 sq. cms.	> 6 sq. cms.

**MAIN CAUSES:**  
- Improper scouring.  
- Unclean doctor blade and printing roller.  
- Doctor blade not properly aligned.

**MENDING:**  
Non - mendable

### 3. Dye bar



### 4. Blurred or dark patch



## 5. Bowing

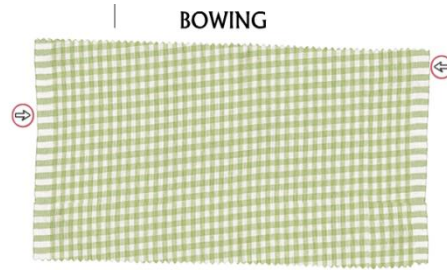

**Bowing:** Bowing is a condition of the fabric wherein the warp and weft yarns do not keep at right angles to each other.

MINOR	MAJOR	SERIOUS
< 5% of the cloth or design, upto 15 cms along the length.	> 5% of the cloth or design, upto 15 cms along the length.	> 5% of the cloth or design, > 15 cms along the length.

**MAIN CAUSES:**

- Improper stretch during scouring, dyeing or finishing.
- Uneven tensions during weaving or processing.

**MENDING:**

Non - mendable

## 6. Miss print or absence of print



## 7. Dyestuff stain

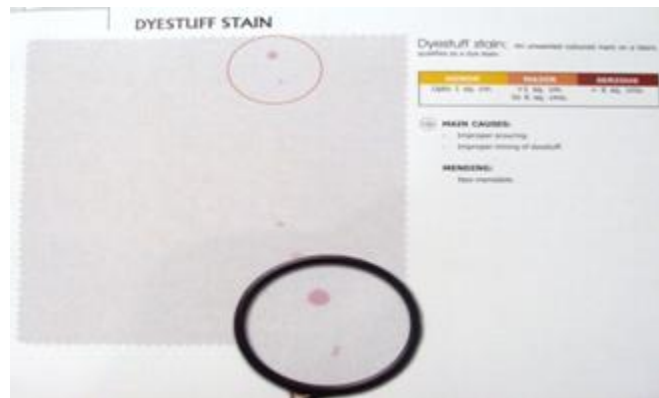

## 8. Uneven printing or tinting



## 9. Patchy or streaky or uneven dyeing



## 10. Pilling



## 11. White spot



## 12. Water Mark



### Fabric defects in Knitted fabrics

#### 1. Bariness

**Bariness : A fabric defect characterized by textural bands or color bands in the course direction of a weft knitted fabric.**

**CAUSES :**

- Use of irregular yarn having higher long term irregularities.
- Using different count thread.

**MENDING:** Non Mendable.

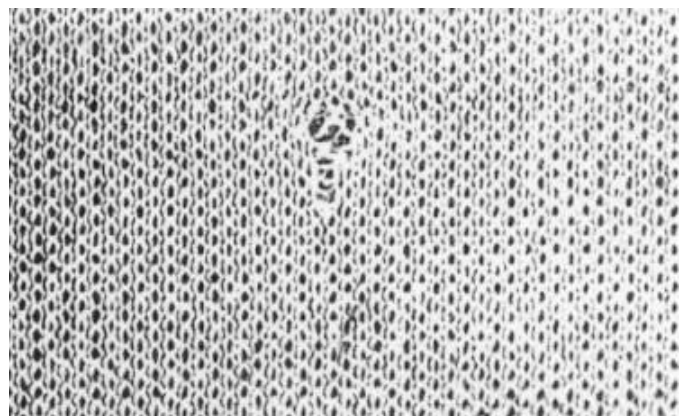

## 2. Bunching up

Bunching up : This is largely influenced by take-up mechanism and whether it functions properly or not.

CAUSES :

- Fabric take-up too weak.
- Thick place in yarn.

MENDING: Non Mendable.



## 3. Drop stitch

Drop stitch: Local column of dropped stitches.

CAUSES :

- Yarn guide not set properly (i.e yarn is not fed properly during loop formation).
- Defective latch needle.
- yarn tension is not sufficient.
- Take-down is too high.
- Wrong yarn threading.

MENDING: This fault can be corrected by stitches reforming using a simple needle.

CAN BE AVOIDED BY:

- Precise yarn-guide setting.
- Needle change.
- Dial position readjustment.
- Use of fabric fault detector.

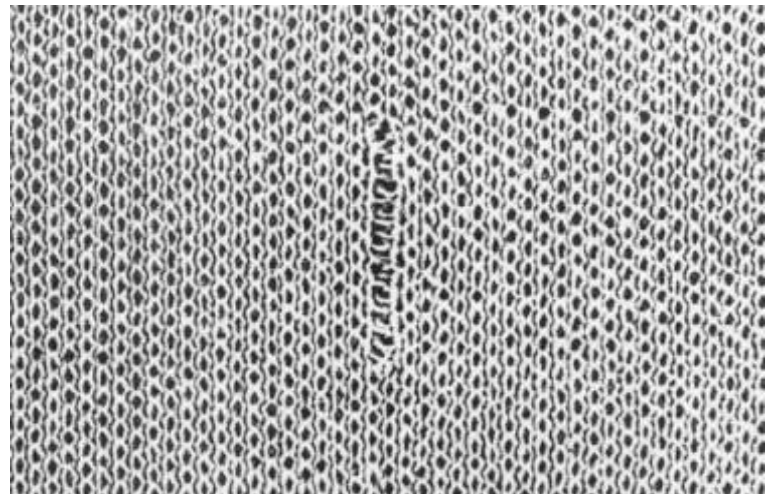

#### 4. Holes or Crack

Holes or crack : Local holes obtained when yarn breaks during loop formation.

CAUSES :

- Relation between cylinder and dial loop not correct.
- Weak places in yarn, Which breaks during loop formation
- Knots.
- Yarn running tension is too high.

CAN BE AVOIDED BY :

- Use of flat knots.
- Accurate yarn guide setting.
- Use of fabric fault detector.
- Use of yarn having lower hairiness.

#### 5. Crack fall out

It is an area consisting of drop stitches lying side by side. Here the yarn is not stitched by several needles laying near to each other.

CAUSES :

- Yarn brakage.
- It can also occur after a drop stitch especially when an empty needle with closed latch runs into yarn feeder and removes the yarn out of the hooks of following needles.

MENDING: Non mendable.

## 6. Horizontal stripes

Are caused by unevenness in the courses. They traverse horizontally and repeat themselves regularly or irregularly.

CAUSES :

- Yarn feeder set badly.
- Differences in the yarn running-in tension.
- Jerky impulse from fabric take up .

Mending : Non mendable.

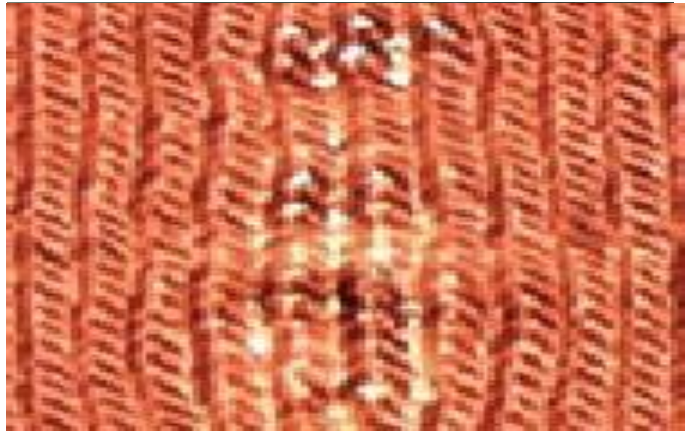

## 7. Vertical stripes

They can be observed as longitudinal gaps in the fabric. The space between adjacent wales is irregular.

CAUSES :

- Bent needles.
- Heavily running needles.
- Damaged latch needle.
- Damaged needle hook.
- Damaged dial or cylinder.

CAN BE AVOIDED BY :

- Needles and sinkers change after long time use.
- Use of fabric fault detector.

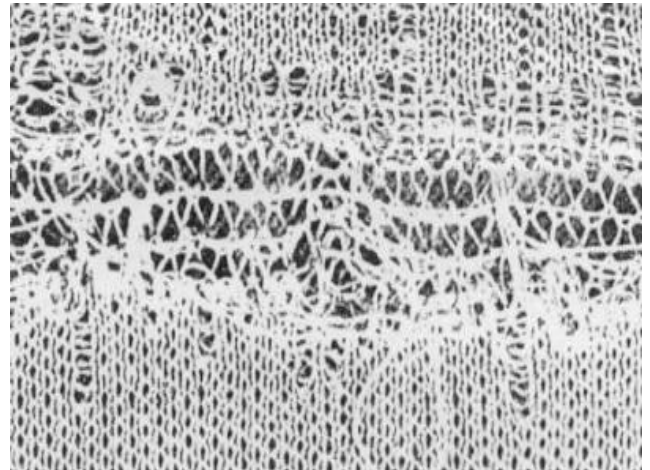



## 6. REQUIREMENTS FOR VISUAL INSPECTION

- Inspection scheme.
- A flat table of sufficient width or perch in a well illuminated place.
- Inspection equipments like calibrated counting glass, measuring tape, weighing machine etc. Opening & repacking facilities

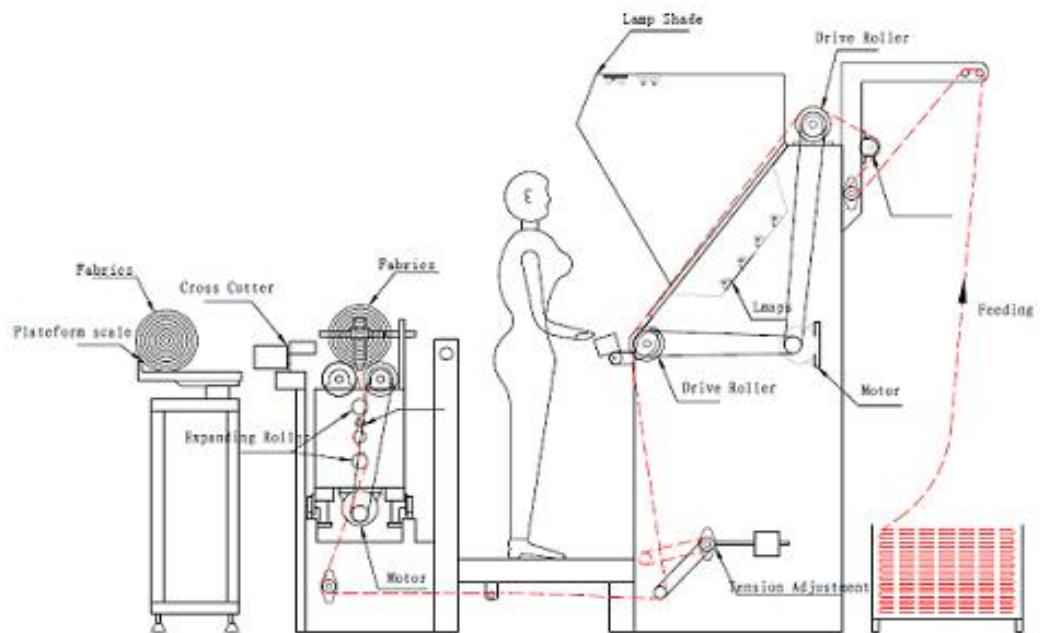

## 7. Checking of dimensions

**Measurement of width:** Width shall be measured at 3 different places or as required and recorded.

While measuring width, care should be taken

- To remove the wrinkles/creases gently from the fabric surface.
  - Keep the measuring tape straight across the fabric horizontally from selvedge to selvedge/end to end.
  - Width should not be measured as far as possible at the fabric roll ends.
- Fabric should not to be stretched while measuring.

- **Ends per inch:** Ends per inch shall be counted at 2 places along the width of the fabric and recorded.
- **Picks per inch:** Picks per inch shall be counted at 3 places along the length



of the fabric and recorded.

**Care should be taken** while placing the pick glass to see that the edges of the template should coincide with the yarn. Ends/Picks per inch may be counted for 1 inch. Also the ends/picks should not be counted at defective places like missing ends, weft bars, cracks etc.

## 8. Inspection:

Inspection is the process of identifying and mending the defects. It is visual examination of fabric

### REASONS WHY INSPECTION IS CARRIED OUT:

- To remove defects.
- To minimize the future reoccurrences of the defect.
- To determine quality and hence the price of the fabric.
- To supply information to proper levels of management as to the qualities being produced.



## 9.0 TYPES OF INSPECTION SYSTEMS

### FLAW GRADING SYSTEM

**Minor & Major Flaws:** Occurring more than one in number within a length of 15 cm of the cloth shall be reckoned as one flaw only.

**Major Flaws:** Major flaws occurring in a consecutive length beyond 15 cms shall be reckoned as one major flaw each for every 15 cms or part thereof. This will not apply to major flaws where linear magnitude has been limited to 15 cms e.g. **Prominent slubby weft, dye bar.**

Sample size in metres	Acceptance number of major flaws		Sample size in metres	Acceptance number of major flaws	
	Standard 'A-1'	Standard 'A'		Standard 'A-1'	Standard 'A'
1200	29	40	625	14	19
1175	28	39	600	13	18
1150	27	38	575	12	17
1125	27	37	550	12	16
1100	26	36	525	11	16
1075	25	35	500	11	15
1050	25	34	475	10	14
1025	24	33	450	9	13
1000	23	32	425	9	12
975	23	31	400	8	11
950	22	31	375	7	11
925	22	30	350	7	10
900	21	29	325	6	9
875	20	28	300	6	8
850	20	27	275	5	7
825	19	26	250	4	6
800	18	25	225	4	6
775	18	24	200	3	5
750	17	23	175	3	4
725	16	23	150	2	3
700	16	22	125	2	3
675	15	21	100	1	2
650	14	20			

Minor flaws: @ 25 per 100 metres maximum are acceptable.  
 Serious flaws: No serious flaw is acceptable.

#### **4-POINT SYSTEM**

- This system also called the American Apparel Manufacturers Association (AAMA) point grading system for determining fabric quality, is widely used by producers of apparel fabrics and by the Department of Defense in the United States and is endorsed by the AAMA as well as ASQC.
- Defects in fabrics are scored with penalty points of 1, 2, 3 and 4 according to the Size and significance of the defect.
- **Acceptability criteria for defects:** Normally fabric containing up to **40** points per 100 sq yds. are acceptable. However, based on the price line and end product more or less than 40 points per 100 sq. yds. may be accepted.

<b>DEFECT SIZE</b>	<b>PENALTY</b>
<b>3 inches or less</b>	<b>1 Point</b>
<b>Over 3 inches, but less than 6</b>	<b>2 Point</b>
<b>Over 6 inches, but less than 9</b>	<b>3 Point</b>
<b>Over 9 inches</b>	<b>4 Point</b>

- No more than 4 penalty points can be assigned for any single defect.
- No linear yard or meter can contain more than 4 points, regardless of the number of defects within that yard or meter.
- Each full width defect should assign 4 points.
- Noticeable and severe defects are to be assigned 4 points for each yard or meter in which they occur, regardless of size.

Advantages of 4 point system :

- ✓ Worker can easily understand it
- ✓ It has no width limitation

### 10-POINT SYSTEM

- This system assigns penalty points to each defect depending on its length and whether it is in the warp (ends) or weft (fill) direction.
- The Ten-Point System is somewhat complicated because points-per-length vary for warp and weft defects. Grading of defects: Fabric flaws or defects are assigned point values based on the following:

Length of defect	Points allotted
<b>Warp defects</b>	
Up to 1 inch	1
1 to 5 inch	3
5 to 10 inch	5
10 to 36 inch	10
<b>Filing defect (weft defect)</b>	
Up to 1 inch	1
1 to 5 inch	3
5 inch to half-width	5
Larger than half-width	10

No linear yard of fabric is assigned more than 10 points, no matter how bad or frequent the defects are.

- **Acceptability criteria for defects:**

- In the case of fabrics up to 50 inch wide, it is considered acceptable, if the number of defect points scored is less than the number of yards of fabric inspected.
- In the case of fabrics wider than 50 in., the fabric is considered acceptable, if the total defect points do not exceed the number of yards of fabric inspected by 10%.