

TABLE OF CONTENTS

S.No.	Contents	Page No.
1.	Basic Textiles terms	1
2.	Embroidery	1
3.	Identification of parts of embroidery machine	2
4.	Preparation before starting Embroidery Machine	5
5.	Threading on Machine	6
6.	Embroidery stitches	7
7.	Seam practice on different patterns	17
8.	Types of Needle used to sewing Different fabrics	20
9.	Methods of Transferring designs on the fabric	22
10.	Frame fitting practices	23
11.	Different Types of Embroidery Threads	24
12.	Embroidery defects	25
13.	Maintenance of Embroidery machines	28
14.	Safety measure	29

1. Basic Textiles terms

Yarn	Basic raw material for weaving/Knitting
Type of yarn	Single ply, double ply and multiply
Yarn count	Defines thickness of yarn. Higher the count, finer the yarn
Warp	Lengthwise yarn in the fabric.
Weft (filling)	Width wise yarn in the fabric.
Selvedge	Edges of the fabric running lengthwise
Woven Fabric	Woven fabrics are made by using two or more sets of yarn interlaced at right angles to each other.
Knitted Fabric	Knitted fabrics are formed by series of interlocking loops (example: knit wears)
Sewing Thread	Sewing Thread is a type of yarn used for sewing.

2. Embroidery

- Embroidery is a craft by using a needle, thread or yarn sewn on to a base material or fabric to create a pattern.
- This is done by hand or machine. It involves the use of special threads available in many colors that help to produce various beautiful patterns.
- There are several different forms of embroidery, in which the design is stitched on top of the base material or the thread is worked through the base material to form a flat pattern on the original fabric.
- Another popular method called drawn thread or cutwork which is often used in lace making. In this form, part of the base material is cut out and the resulting hole is stitched over with lace or embroidered with thread or yarn.

➤ **Sequence of Operations In Garment production**

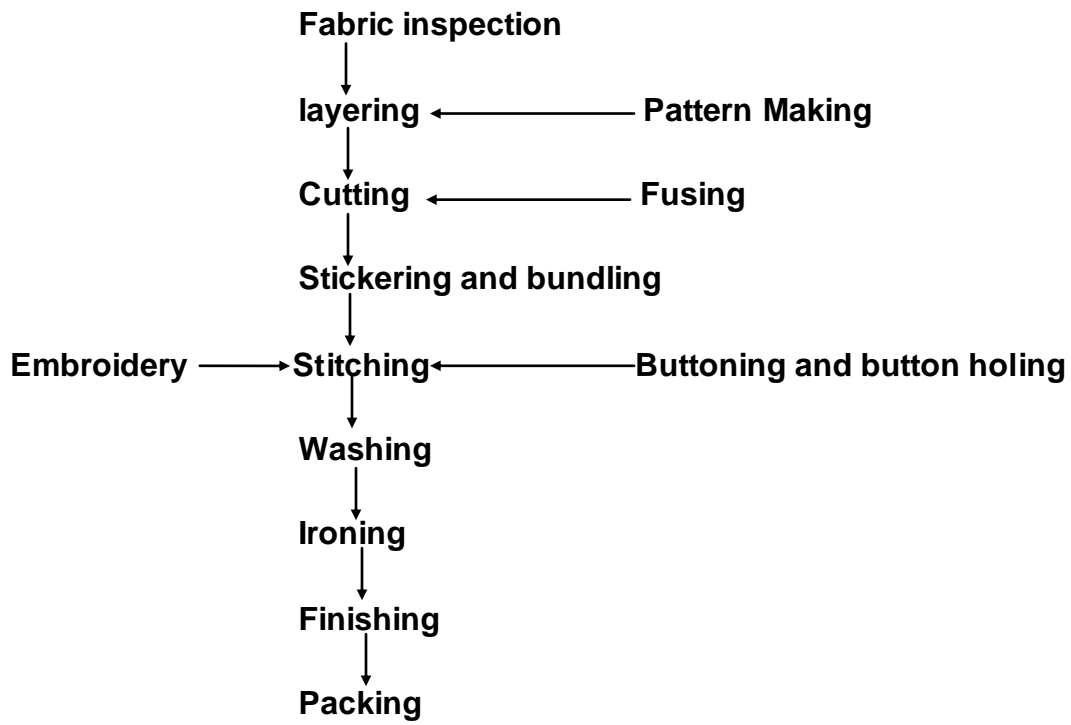

3. IDENTIFICATION OF PARTS OF EMBROIDERY MACHINE

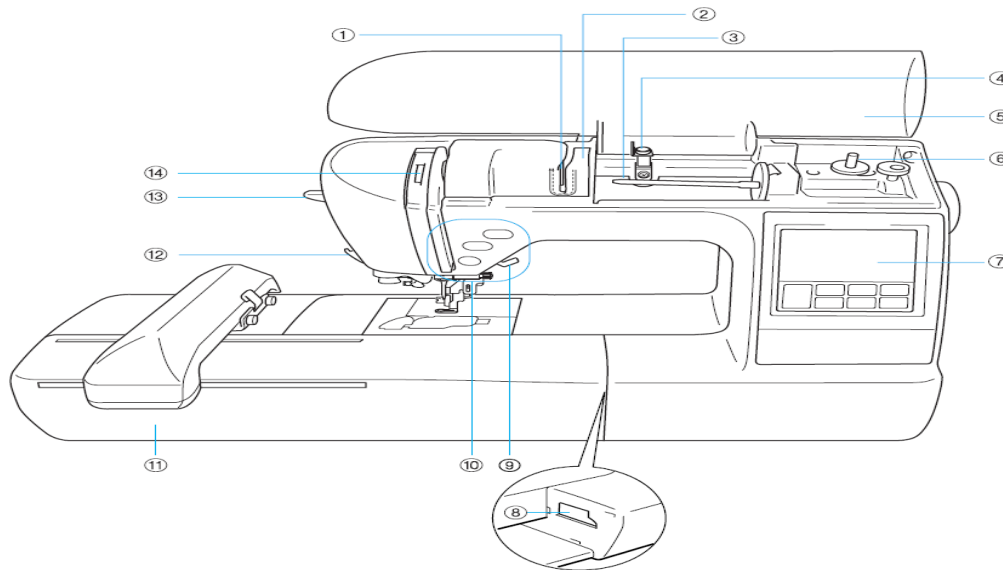

1 **Thread guide** – Pass the thread around the thread guide plate when threading the upper thread.



2 **Thread guide cover** – Like threading through the thread guide plate, pass the thread around the thread guide cover when threading the upper thread.



3 **Spool pin** – Place a spool of thread on the spool pin.



4 **Bobbin winding thread guide** – Pass the thread around this thread guide when winding the bobbin thread.



5 **Top cover** – Open the top cover to place the spool of thread on the spool pin.



6 **Bobbin winder** – Use the bobbin winder when winding the bobbin.



7 **Display panel** – It displays current operations of the machine. From the display panel patterns can be selected and edited.



8 **Embroidery unit connector slot** – Plug in the connector for the embroidery unit.



9 **Presser foot lever** – Raise and lower the presser foot lever to raise and lower the presser foot



10 **Operation buttons** – Use these buttons to operate the machine.



11 **Embroidery unit** – Attach the embroidery unit to the machine, and then attach the embroidery frame.



- 12 **Thread cutter** – Pass the threads through the thread cutter to cut them.



Automatic
Thread Cutting

- 13 **Needle threaded lever** – Use the needle threader lever to thread the needle.

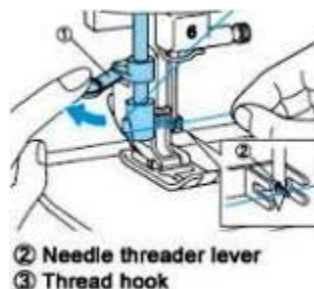

- 14 **Thread take-up lever check window** – Look through the window to check the position of the take-up lever.

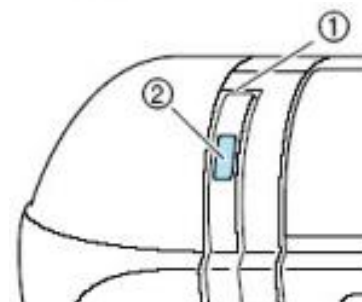

4. Preparations before starting Embroidery Machine

The basic steps for embroidery are as follows.

Pressure Foot Attachment – Attach the embroidery foot.



Checking the Needle – Use a needle matched to the fabric.



Embroidery Unit Attachment – Attach the embroidery unit.



Bobbin Thread Set Up – For the bobbin thread, wind embroidery bobbin thread and set it in place.



Fabric Preparation – Attach a stabilizer material to the fabric, and hoop it in an embroidery frame.



Embroidery Frame Attachment – Attach the embroidery frame to the embroidery unit.



Pattern Selection – Turn the power on, and select an embroidery pattern.



Checking the layout – Check and adjust the size and position of the embroidery.



Embroidery Thread Set Up – Set up embroidery thread according to the pattern.

5. Threading on Machine

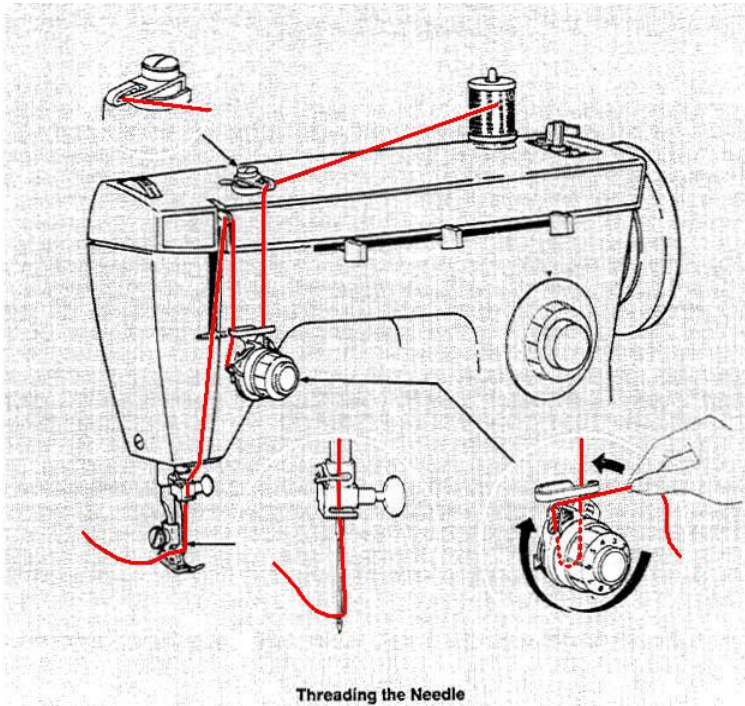

THE NEEDLE THREAD

1. Raise presser-foot lifter to release needle-thread tension discs.
2. Place spool of thread on spool pin over the spool pin felt.
3. Turn hand wheel toward you to raise the needle to its highest position.
4. Lead thread through all threading points as shown, making sure to:
 - Hold thread taut while threading tension discs.
 - Thread the tension discs by leading thread down behind the thread guide, between and around tension discs, and up under spring on left side of assembly. Pull thread gently up and to the right, lifting the spring and allowing thread to slip into spring thread guard. Then lead thread up behind thread guide.
 - Thread take-up lever from right to left.
 - Lead thread through all remaining threading points.
 - Thread the needle from front to back, and draw about four inches of thread through eye of needle.



Threading on Embroidery m/c Step 1



Threading on Embroidery m/c Step 2



Threading on Embroidery m/c Step 3



Threading on Embroidery m/c Step 4

6. Embroider Stitches:

The stitches are grouped into four types, each offering different effects and uses for embroidery:

- **Outline** – Used for outlining the elements of your design
- **Border** – Used to secure edges and to add textural dimension to your design
- **Detached** – Used to create decorative details or in mass to fill in open areas of the design
- **Filling** – Used to create shading or to solidly fill in a design area

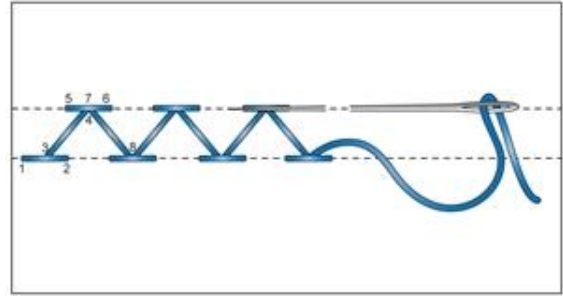

Running Stitch

Uses: outlining, straight and curved lines.

- Work from right to left.
- Bring thread up at 1 then down at 2, up at 3 and down at 4 and continue.
- The spaces between the stitches can be the same length as the stitches or shorter for a different look.

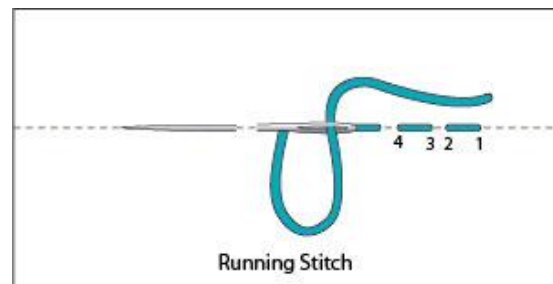

Back Stitch

Uses: outlining, straight and curved lines

- Work from right to left.
- Bring needle up at 1 and back down at 2.
- Move left and bring needle up at 3, then back down at 1. Continue stitching.

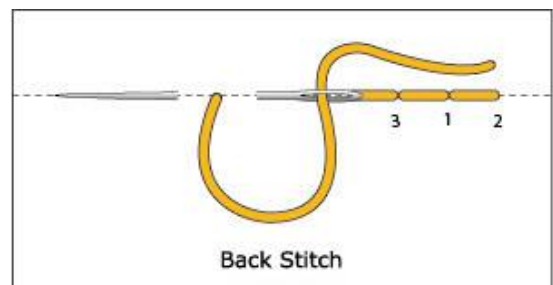

Split Stitch Uses: Outlining, straight and curved lines, filling a shape by working rows closely together.

- Work from left to right.

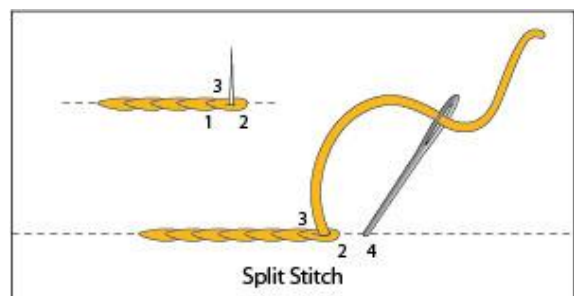

- Bring needle up at 1 and down at 2.
- Bring needle back up at 3, splitting the center of the previous stitch.
- Take needle down at 4 and then back up at 2.
- Continue stitching.

Stem Stitch

Uses: Outlining, straight and curved lines, stems for plants, filling if rows are stitched closely together. Creates a rope like appearance.

- Work from left to right.
- Bring needle up at 1 and down at 2.
- Bring needle back up halfway between 1 and 2 at 3, just slightly above the first stitch.
- Be sure to keep thread below the needle.
- Continue stitching

Chain Stitch

Uses: Outlining, straight and curved lines, filling if rows are stitched closely together.

- Work from top to bottom.
- Bring needle up at 1 and then reinsert needle in same hole, forming a loop.
- Bring needle up at 2 and pull thread to tighten loop until desired shape is achieved.
- Repeat multiple stitches to create a chain.
- To end the row make a small stitch over the last loop to hold it in place to secure thread on backside.

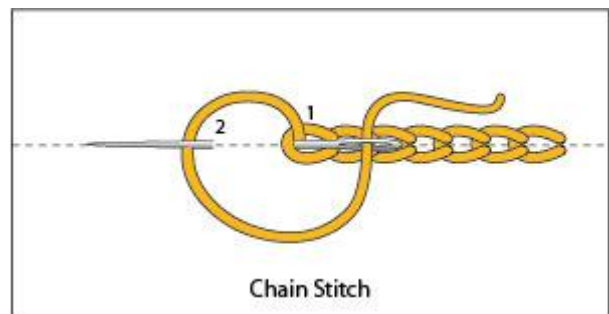

Couching

Uses: Outlining shapes, straight and curvy lines, spirals, bold dimensional accents, decorative borders.

This stitch involves two threads: a thicker foundation thread, (also called the laid thread) and a thinner thread (called the couching thread).

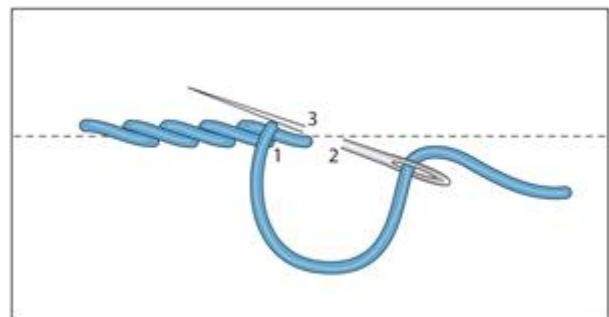

- Bring foundation thread onto the front and place along the design line.
- Bring the couching thread up under the foundation thread and make a tiny stitch over the thread, going back into or very close to the entry hole.
- Continue making evenly spaced stitches over the foundation thread to anchor the foundation thread in place.
- To finish couching, bring the foundation thread onto the backside and secure it.
- Secure couching thread on backside.

Blanket Stitch

Uses: Straight and gently curved lines, borders and finishing edges.

- Work from left to right.
- Bring needle up at 1, down at 2 and up at 3, keeping the thread looped under the needle.
- Pull thread through and shape stitch as desired.
- Repeat multiple stitches until complete.

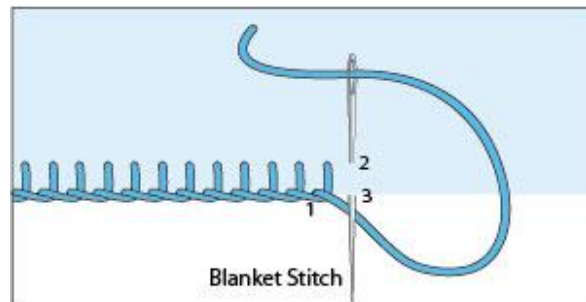

Whip Stitch

Uses: is used for seaming fabrics, either right or wrong sides together. The stitches should be about 1/16" apart, and only as deep as necessary to create a firm seam.

- Bring needle up at 1 and down at 2 making sure to pierce both pieces of fabric to bind together.
- Bring needle back up at 3 and down 4, continue stitching the seam.

Ladder Stitch

Uses: Applique, bind two seams together.

- Bring needle up at 1 and through the fabric a short distance to 2, keeping the thread hidden under the fabric (dashed lines).

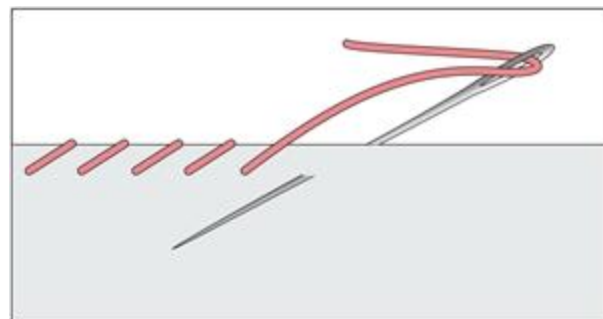

- Bring needle over to 3 and repeat.
- Only the vertical stitches should show on the front of the fabric. Stitches indicated by dashed lines will be hidden in the base fabric, or in the folds of the appliqué.
- Continue stitching.

Laced Running Stitch

Uses: Borders, decorative outlining.

- Stitch a line of Running Stitches.
- Bring the lacing thread up at 1 and lace it under the next running stitch.
- Continue lacing the thread up and down through the running stitches keeping the loops even.
- To finish the lacing, bring the lacing thread onto the backside under the center of the last stitch.

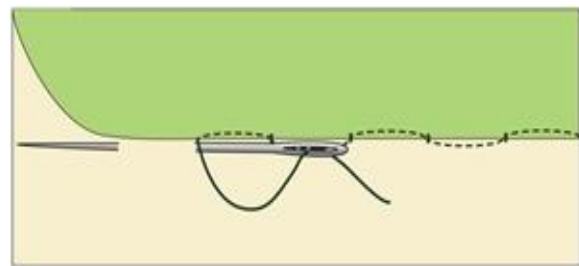
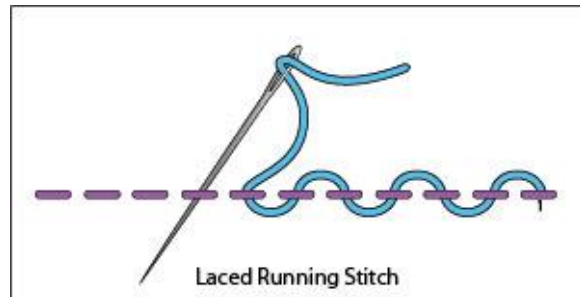

Coral Stitch

Uses: Decorative borders, foliage, plant stems

- Working from right to left, hold the working thread to the left of the starting point (or the last stitch). Insert the needle into the fabric above the working thread and bring the tip of the needle out just under the thread. Wrap the thread around the needle from left to right and pull the needle through the resulting loop.

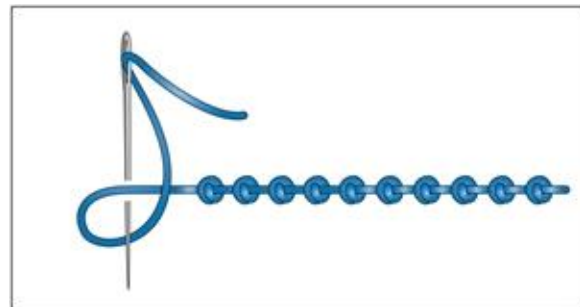

Cross Stitch

Uses: Borders and filling if worked in adjacent rows.

To stitch a line:

- Stitching from left to right, bring needle up at 1, down at 2, then up at 3 and down at 4.
- Continue stitching across to end of line.
- Start back stitching from right to left, make crosses by bringing the needle up at 5 and down at 6. Continue until all crosses have been stitched.

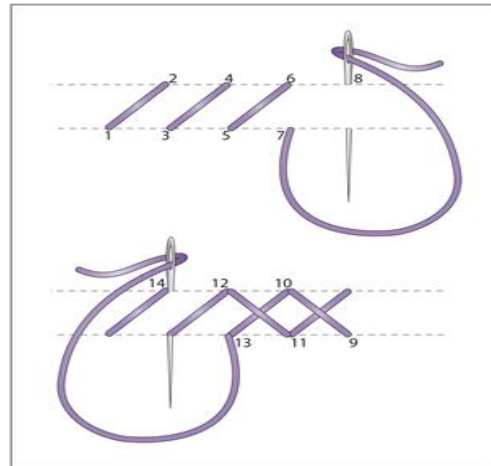

Upright Cross Stitch

Uses: Borders, fillings, decorative.

- Work left to right.
- Create a horizontal stitch by bringing needle up at 1 and down at 2.
- Create a vertical stitch by bringing your needle up at 3 and down at 4.
- To create the next upright cross stitch bring your needle up at 5 and down at 6.
- Bring your needle back up at 7 and down at 8.
- Continue stitching.

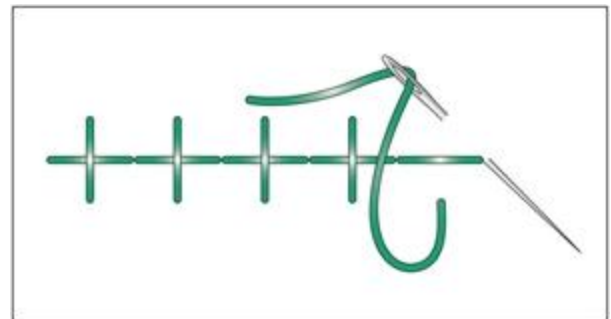

Herringbone Stitch

Uses: Border, edging, can be stitched over a ribbon or braid to hold it down.

- Work from left to right.
- Bring needle up at 1, and down at 2.
- Bring needle up at 3 and down at 4 to create an elongated cross stitch.

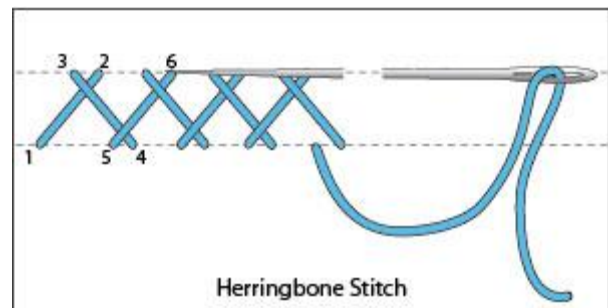

- Bring needle up at 5 and continue.
- Mark two parallel lines with Water Soluble Pens to keep stitch height uniform.

Chevron Stitch

Uses: Border, edging, can be stitched over a ribbon or braid to hold it down.

- Work from left to right.
- Bring needle up at 1, down at 2.
- Bring the tip of the needle back through the fabric halfway between 1 and 2 at point 3.
- Bring the needle up to 4 and make a backstitch by bringing your needle up from 5 down at 6.
- Bring the tip of your needle back through the fabric halfway between 5 and 6 at point 7.
- Bring your needle down at 8 and repeat the stitching sequence.

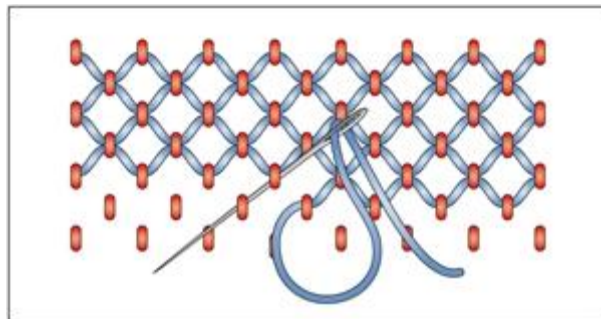

Cloud Filling Stitch

Uses: Filling in spaces

- Lay a groundwork of small, evenly spaced vertical stitches, alternating the placement of the stitches as shown in the diagram.
- Weave your thicker secondary thread through the network of stitches in rows.
- When starting from the right, thread the needle under the first vertical stitch, then bring your needle through the vertical stitch to the lower right. Next, thread your needle under the next vertical stitch to the upper right. Continue stitching in a zig-zag motion to the end of the row.
- Work the next row in the opposite direction.

Feather Stitch

Uses: Decorative border edges, seam embellishment, foliage and stems.

- Work vertically, from top to bottom.
- Bring needle up at 1 and back down to right at 2, leaving a loop on the front.
- Bring the needle back up at 3 and pull thread to shape loop as desired.
- Insert the needle to the right of 4 at 5, leaving a loop of thread on the front.
- Bring needle up at 6 and pull thread to shape loop.
- Take next stitch to the left and continue stitching.
- To finish, take a small stitch over the last loop.

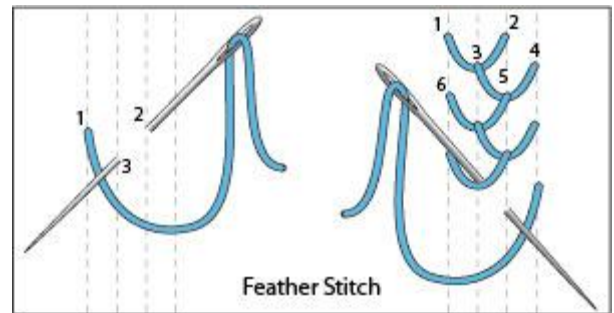

Lazy Daisy Stitch (Detached Chain Stitch)

Uses: Stitch in a circle to create flowers, single stitches can be leaves.

Similar to the chain stitch, but the loops are “detached” instead of connecting.

- Come up at 1 and back down in the same hole or right next to point 1, forming a loop on the front side.
- Bring needle up at 2 and pull thread to shape loop into desired shape. Pulling tighter creates a straighter looking stitch, while a looser thread creates a more rounded loop.



Fly Stitch

Uses: Stitch in rows for edging or singly for accents, plants and foliage, decorative lines, interesting filling.

- Bring needle up at 1 and down at 2, leaving a loop.

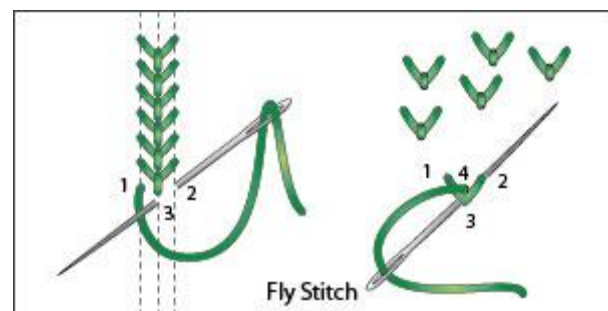

- Come up at 3 and with the needle over the loop, pull the thread to shape a V.
- Go down at 4 to anchor the V shape.

Seed Stitch

Uses: Filling spaces, flower centers, background textures like leaves, snow and sand.

Two small straight stitches side by side and randomly placed to fill an area.

- Come up at 1 and down at 2.
- Come up at 3 and down at 4.
- Continue grouping stitches together randomly and at different angles to look like they are scattered like seeds.

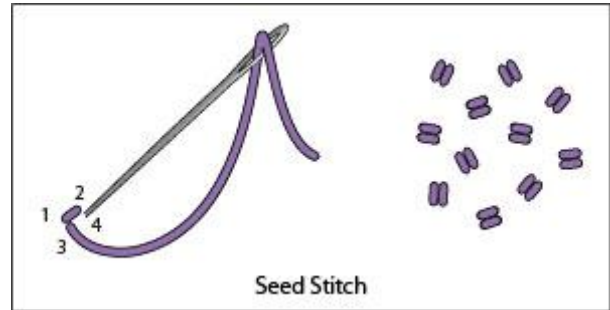

French Knot

Uses: Decorative dots, filling flower centers, leaves, plants, eyes.

- Bring needle up at 1.
- Hold thread taut with other hand and wrap the thread twice around end of the needle.
- Gently pull the thread so that the wrapped threads tighten and while holding it taut, insert the needle next to 1.

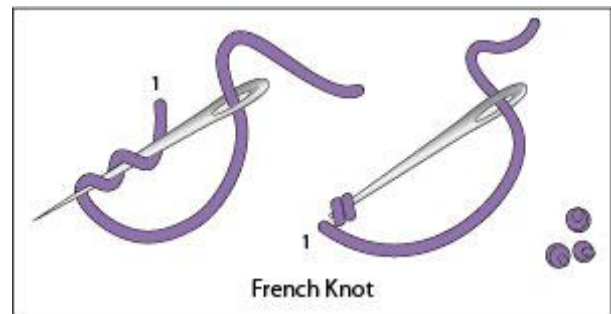

Pull thread through onto the backside until the knot is formed and lies securely on the surface.

Bullion Knot

Uses: Decorative dots, leaves, plants

The Bullion Knot is very similar to the French Knot, but you loop the thread around the needle more times, producing a worm of a knot that is inserted a slight

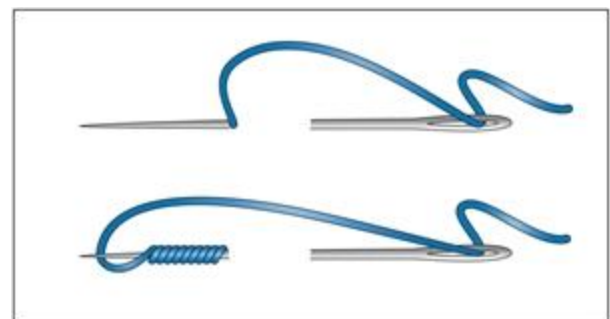

distance from the needle's original entry point.

- Make a back stitch, the length of the bullion knot required.
- Bring the needle out at 1, but do not bring it out all the way.
- Twist the thread around the needle point, as many times as is necessary to equal the length of the back stitch.
- Holding the left thumb on the coiled thread, turn the needle back to 1 and insert it in the same place. Pull the thread through until the bullion knot lies flat.

Colonial Knot

Uses: Use alone as decorative accents, or stitch close together to form lines and or fill in shapes.

- Bring need up through fabric and wrap the thread up, over and behind the needle forming a figure 8 around the needle.
- Insert the tip of the needle back through the fabric, close to where it first came up, but not in the same hole. Pull the thread carefully until a knot is formed, then push the needle to the back and pull the thread through.



Star Stitch

Uses: Decorative accents, stars, flowers, in a row for a border, disperse randomly for loose filling or stitch close together for denser filling.

- Starting at the top, bring the needle up at 1 and down to the center at 2.
- Bring the needle up at 3 and down to center at 2.
- Continue stitching in a clockwise direction until you have 8 evenly placed stitches to create a star.

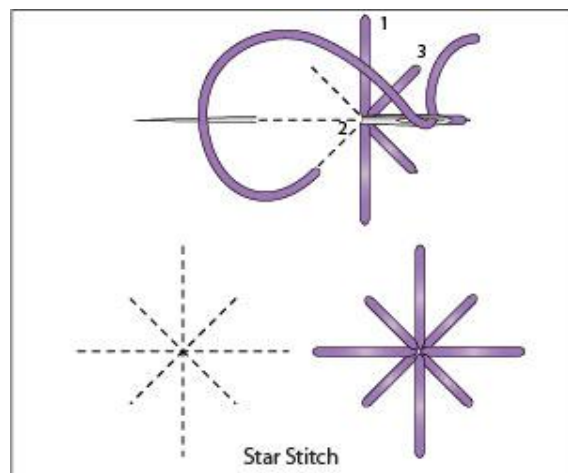

Satin Stitch

Uses: Solid filling for shapes, great for monograms

- Bring needle up at 1, down at 2, then back up right next to 1 and down right next to 2.
- Place stitches closely together to fill in area.
- Be sure the thread lays flat and without any twisting to produce a smooth look.

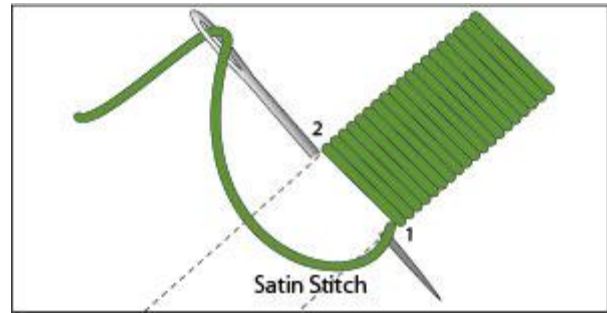

Padded Satin Stitch

Uses: Solid filling for shapes.

- Stitch a cluster of seed stitches.
- Stitch the satin stitch over to create a beautiful raised look.

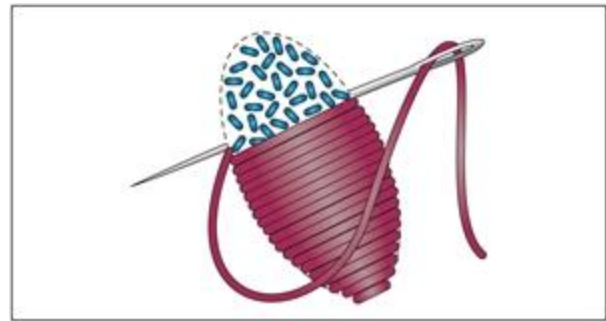

Long and Short Stitch

Uses: Filling of larger shapes especially when color shading is desired.

- First work a row of alternating long and short Satin Stitches. Keep the upper edge of the design line even.
- Next work a second row of long even length stitches into the short stitches of the first row, passing the needle through the tip of the stitch above.
- Continue stitching rows until the shape is nearly filled and the last row of long stitches are worked along the bottom of the design line.
- Stitch the last row with short stitches to fill in the open area along the bottom.

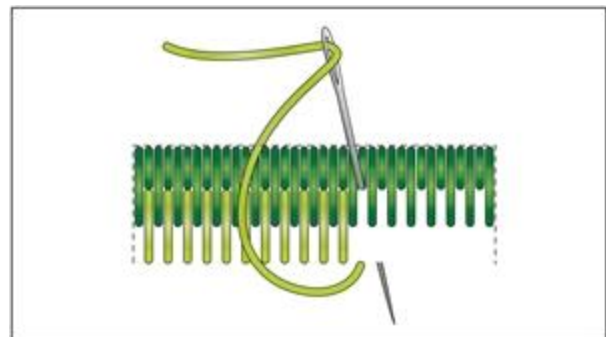

7. SEAM PRACTICE ON DIFFERENT PATTERNS

Straight seams

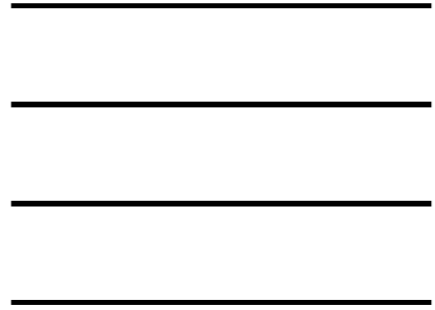

Straight seams end at a cross seam

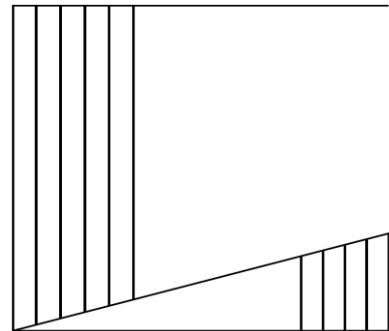

Straight seams with bartacking stitches

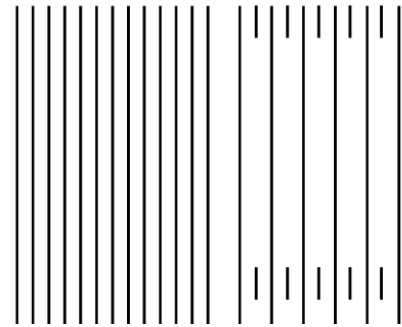

Meander seams, arched and sinusoidal seams

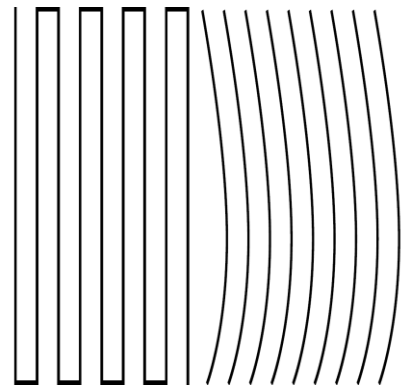

Short zigzag seams

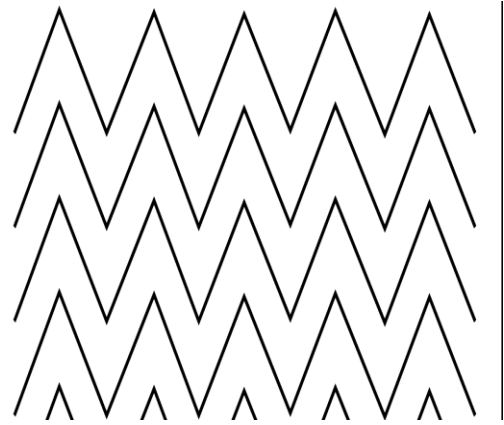

Curved seams in left and right sewing direction

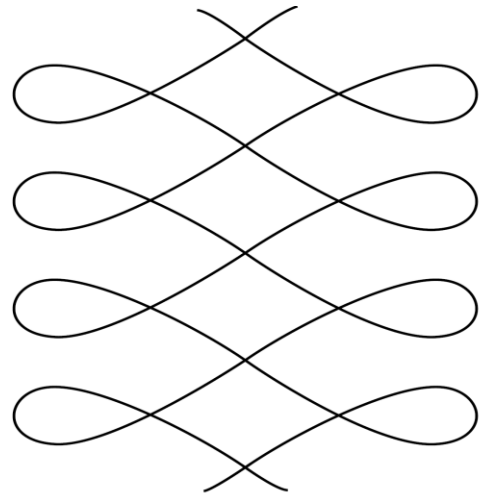

Spiral seams

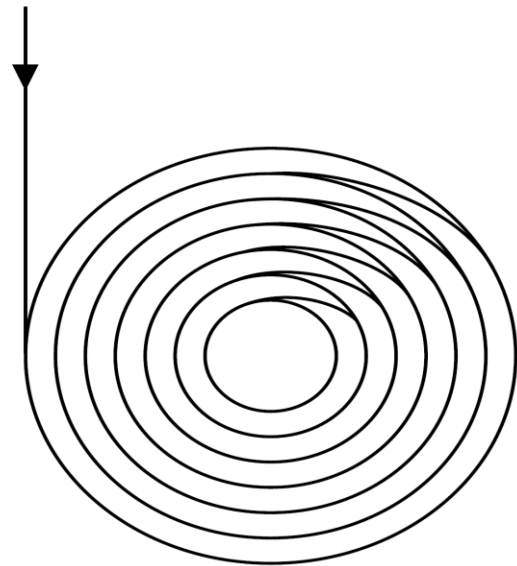

Sinusoidal seams

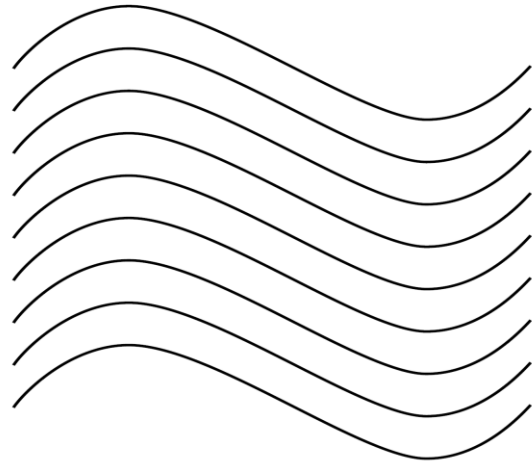

Various decorative stitches of shoe branch

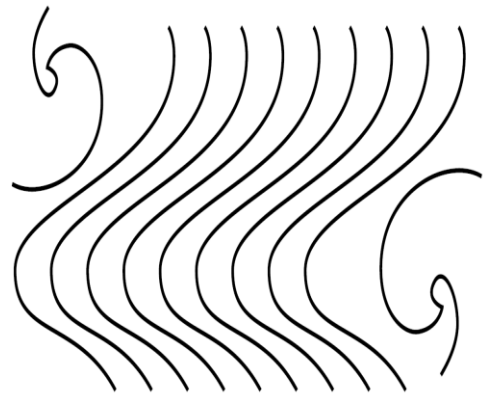

Decorative stitching on pockets

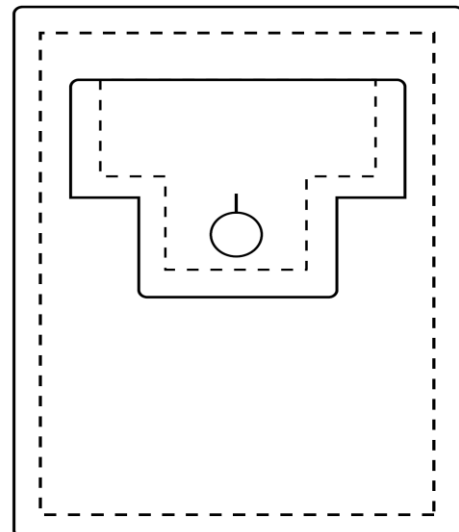

8. Types of Needle used for sewing Different fabrics

Select the type of needle based on the textile construction (i.e knit vs woven), and the needle size is determined by the thickness of the thread and the weight of the fabric used for sewing.

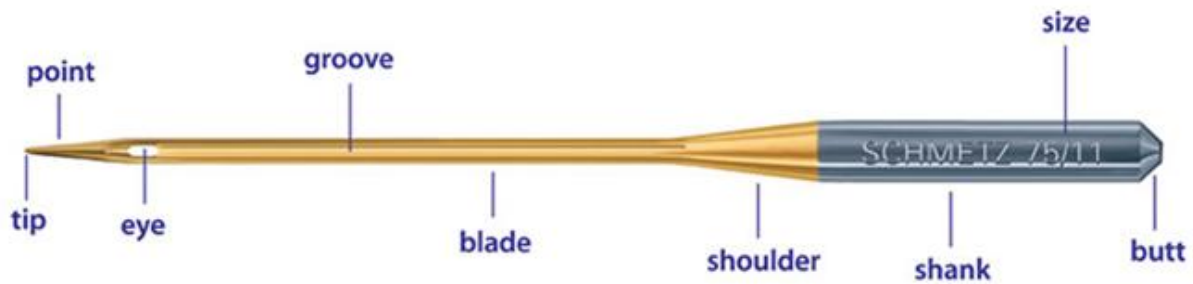

There are two needle sizing system :American and European. American Needle sizes range from 8 to 19, and European sizes range from 60 to 120. Larger the number, the larger the blade of the needle.

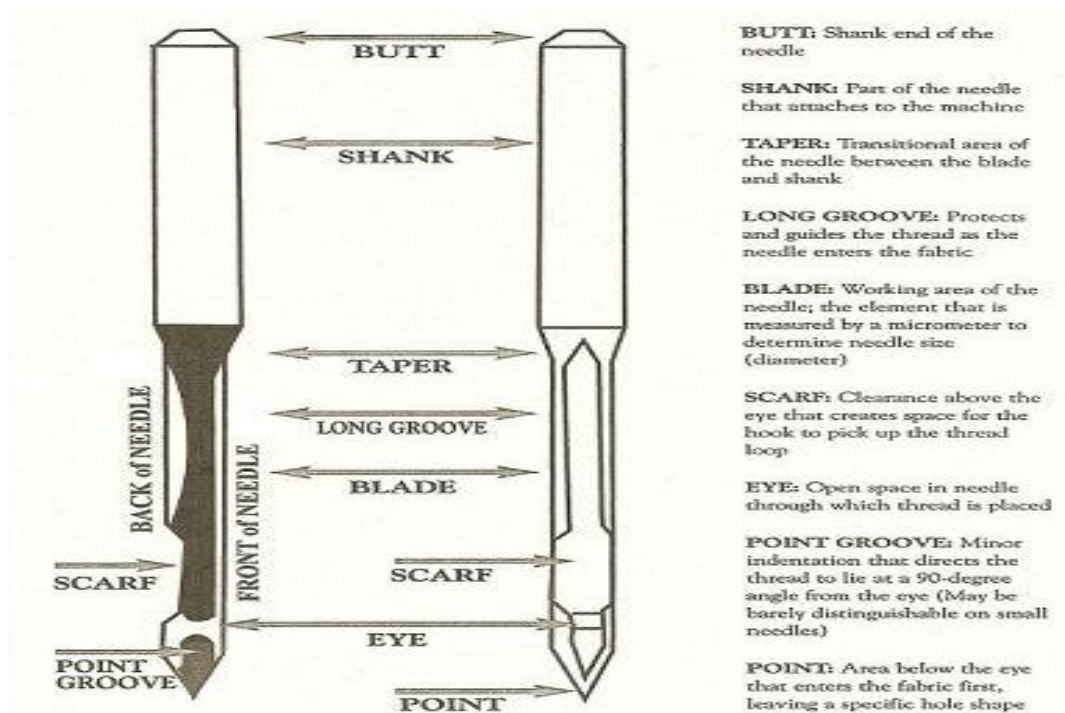

Commonly used needles for Embroidery and their uses as below:-

Needle	Fabric Uses	Sizes	Description
Machine Embroidery	For embroidery	70/10 – 90/14	Machine embroidery needles have a larger eye and specially designed scarf that protects the thread against breaking or shredding, even when stitching dense designs. Use for machine embroidery with rayon, acrylic or specialty threads.
Metallic	For use with metallic threads	80/12	Metallic needles are designed especially for use with metallic threads. This needle features an even larger eye than the embroidery needle, a fine shaft and a sharp point to prevent thread breakage and shredding. It has a special, large-groove scarf designed to protect the thread and to prevent skipped stitches. It's also ideal for use with monofilament thread.

Determining the Right Needle for a Thread

Here's a quick way to determine if the thread and the sewing machine needles are compatible:

1. Take half a metre of the thread being used on the machine and thread it through the eye of a loose needle.
2. Hold the thread vertically with the needle at the top.
 - If the needle is too big, it will drop to the bottom of the thread
 - If the needle is too small, it will stick at the top of the thread
 - If the needle is the right size, it will slowly spiral to the bottom of the thread

However, a larger-than-normal needle may have to be used to penetrate thicker fabric, or stitch over the top of pronounced or bulky seams.

9. Methods of transferring designs on the fabric.

There are several different ways of marking an embroidery design on fabric. The choice of techniques can also often depend on the weight or color of fabric being used

1. Use Light

If the fabric is fairly thin, the designs transfer directly onto the fabric using a light source such as a light box or window, marking the lines with a chalk-based marking pencil or water soluble transfer pen or pencil.

2. Transfer Paper

Designs can be transferred to thicker fabrics using carbon- or wax-based transfer paper, often referred to as dressmakers' carbon paper. This lightweight transfer paper is coated on one side with a powdery, colored ink and is made specifically for use on fabrics and will wash out of the finished piece. Use a light-colored piece of carbon paper to mark designs on darker fabrics, and a darker color on lighter fabrics.

3. Heat Transfer Pencils

Heat transfer pencils or pens are also an option for marking an embroidery design on fabric, and will work on both light- and heavier-weight fabrics. To use a heat transfer pencil, trace the design in reverse on a lightweight sheet of paper (the design is traced in reverse because the pressing process creates a mirror image of the design marked on the paper).

4. Hot Iron Transfers

Hot iron transfers are purchased as ready-to-use and feature a wide range of subjects. They are normally printed in blue or gray ink. The designs are transferred to the fabric using a hot iron in the same manner as patterns traced using transfer pens and pencils.

5. Pouncing

Before the advent of transfer paper and iron-on inks, pouncing was a common way to transfer embroidery designs to fabric. Using this method, a paper pattern is pricked with a pin at regular intervals. The pattern is then secured to the fabric and a powdered pigment is worked through the holes in a *pouncing* motion using a soft fabric pad.

Common Practices of design transfer on the fabric in Industry



Putting the design pinned tracing paper on the fabric



Using of Powder Pigment on pinned tracing paper



The design is transferred by using the powder pigment on to the fabric

10. Frame Fitting Practices

1. Place the piece of fabric using a short stitch length, if the fabric is thin fuse a layer of light weight interfacing on the patch wrong side of fabric.
2. Hoop the base fabric with the help of stabilizer.
3. Place the hoop on Embroidery Machine and select the design to embroider.
4. The first segment is the intersection lines for the pieced appliqué placement.
5. Place the seamlines of the patch work line with the stitching on the base fabric. Stitch the outline.
6. Remove the hoop from the machine.
7. Trim the excess fabric from around the outline.

8. Return the hoop to the machine and complete the remaining design.



Putting the frame to fasten the selected fabric area



Using of Fusing material for embroidery on thin or delicate fabrics



Putting the fusing material beneath the fastened fabric in the frame



Start the Embroidery work on fabric

11. Different Types of Embroidery Threads:

Different types of Embroidery threads in use are

Rayon Threads,

Polyester Threads,

Nylon threads,

Cotton Threads,

Cotton-wrapped polyester,

Metallic Threads,

Laminate or Flat Threads and Silk Threads:

12. Embroidery Defects

Poor Registration

DESCRIPTION: Where the stitches and design elements do not line up correctly. The embroidery sewing process sews different colors at different times. If the fabric shifts while one color is being sewn, then poor registration will occur when the next color is sewn. Sometimes it is difficult to tell the difference between poor registration, poor digitizing, and fabric “grin-through” or “gapping” due to thread “pull”.

SOLUTIONS: Generally can be corrected by: 1) Digitizing properly (using appropriate underlay stitches); and 2) Hooping properly (using correct backing to prevent excessive material flagging).



Fabric Grin Through or Gapping

DESCRIPTION: Where the fabric is seen through the embroidery design either in the middle of the pattern or on the edge.

SUGGESTED SOLUTIONS: Generally, can be corrected by: 1) Digitizing properly (Using appropriate underlay stitches, increasing stitch density, using different fill stitch pattern or direction, or compensating for “Pull” of thread by overlapping fill and satin border stitches); and 2) Using appropriate topping.

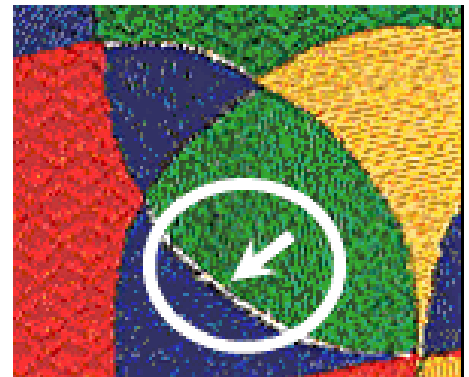

Missed Trim

DESCRIPTION: Where threads are left on the embroidery pattern between images or lettering. Thread trims are digitized when changing colors and when moving from one location to another using “jump” stitches.

SOLUTIONS: Generally, can be corrected by: 1) Digitizing properly (Using appropriate number of trims, using appropriate tie off stitches, or replacing trimming knives when necessary); and 2) Hand trimming the missed trims using trimming snips.

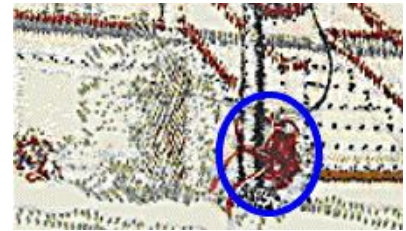

Bunching at Corners

DESCRIPTION: Where the corners of lettering or shapes are not sharp and crisp but are bunched up or distorted. Usually caused by too much thread in the corners due to poor digitizing. This includes: 1) Not using appropriate stitch selection, 2) Not using “Short” stitches in corner, and 3) Poor stitch balance – thread too loose.



SOLUTIONS: Generally, can be corrected by digitizing properly: 1) Using appropriate stitch selection, and 2) Using “short” stitch cornering, and 3) Correcting stitch balance. American & Efird, Inc. 2002.

Poor Stitch Balance

DESCRIPTION: where white bobbin thread shows on the topside of the embroidery. Ideally, the needle thread should be held on the underside of the seam, and not ever be pulled up to the topside. Proper stitch balance can be checked on the underneath or backing side of the embroidery by looking for 2/3 needle thread to 1/3 bobbin thread on Satin stitches.



SUGGESTED SOLUTIONS: Generally, can be corrected by: 1) Using quality embroidery needle thread, 2) Using quality pre-wound bobbins, and 3) Setting machine thread tensions correctly.

Fabric Damage –

Needle Holes

DESCRIPTION: Where the fabric is damaged around the corners of the embroidery. Caused by: 1) Not using the correct type and size of needle; 2) Putting too many stitches in the same location; and 3) Not tearing tearaway backing properly, allowing the fabric to be damaged as the stitches are pulled out.

SOLUTIONS: Generally, can be corrected by: 1) Digitizing properly; 2) Reducing the stitch count in the corners; 3) Using the correct type and size of needle; and 3) Using a ball point needle as small as possible.

Embroidery Too Thick

DESCRIPTION: Where the embroidery is too thick and uncomfortable which can be caused by too high of a stitch density or not using the correct backing for the application.

SUGGESTED SOLUTIONS: Generally, can be corrected by: 1) Digitizing properly (Using appropriate stitch selection, using fewer stitches, and using “short” stitches on corners); 2) Making sure stitch is balanced properly; 3) Using smaller thread size; and 4) Using the correct backing (Using correct type and weight).

Poor Coverage – Poor Stitch Density

DESCRIPTION: Where the stitch density is not thick enough and you can see through the embroidery stitching.

SOLUTIONS: Generally, can be corrected by: 1) Digitizing properly (Using appropriate stitch selection, using more stitches, and using underlay stitches); and 2) Using appropriate backing & topping.



Poor Hooping

DESCRIPTION: Where the fabric around the embroidery looks distorted and does not lay flat.

SOLUTIONS: Generally, can be corrected by: 1) Using appropriate backing & topping, 2) Making sure sewing operators hoop the garment properly without stretching the fabric too much prior to putting it in the hoop, and 3) Pressing or steaming hoop marks.



13. Maintenance of Embroidery machines

- Try to keep your sewing machine covered when not in use. This would ensure you to not let any grime or dirt enter into its crevices. This can be specifically troublesome to computerized ones. Dirt can clog certain parts and cause a lot of damage to the embroidery device.
- Always see to it that it is cleaned regularly. Always unplug the machine, before you begin any assignment. A routine cleaning everyday would keep it in perfect condition. You can use a soft cloth and fold it, so that you can use the folded part of the cloth to clean between the hard to reach areas. Ensure that the pressure foot is up, so that you can clean the tension disks thoroughly.
- Always use a can of compressed air to clean the difficult areas. Never use your breath, as it contains moisture and can cause corrosion to the parts.
- Always get into the habit of cleaning the lint out of sewing machine after every project. This would save you plenty of time when you embark upon a new project.
- Use appropriate sewing machine oil and refer to the instruction manual to know the areas that require oiling. Once you oil the parts, use some old piece of fabric that would cause the oil to run over the fabric, and ensure all the

excess oil is completely out, before you start stitching something new. This would help to lubricate the areas and also reduce the formation of rust on its various parts.

- Always make it a point to remove the needle and dispose it after you complete an assignment. Clean under the feed dogs and bobbin area with a small brush. Use compressed air that can blow out any dirt from the bobbin case. Sometimes the hook mechanism can be removable and before placing it back, you can add a drop of oil to it. Always check your manual to know what kind of oil would suit your device.
- Check the screws and set them. This can be done while you are cleaning the device itself. An easier way would be to tighten the loose screws as you come across them.
- When you choose a bobbin, ensure you find one that suits your device. Always wind them correctly to avoid the threads that may hang from the bobbin. This can even jam the device.

14. Safety Measure:

- When in doubt, ask the instructor.
- Report any injuries or accidents immediately to the instructor. Also, Report a breakage to a tool or m/c to the instructor. If the equipment does not operate properly, notify the instructor immediately.
- Wipe up any oil spillage on the floor immediately to prevent anyone from slipping. Keep aisles clear at all times.
- Operate only the machines you have been trained to operate and when the instructor or supervisor/ assistant is present.
- Operate machines only with permission.
- Always inspect the m/c before starting to work. Be sure it is clean and threaded correctly, with no loose threads on the pulley belt and all guards in place.
- Make only adjustments you have been trained to perform

- When sewing on a power m/c, wear low shoes & close-fitting clothing. Avoid loose fitting sleeves, sweaters, jewellery, ties, and ribbons when operating the machine. If your hair is long, tie it back.
- Always practice proper posture to reduce fatigue, help prevent accidents and increase efficiency. If possible, adjust the chair height so that your feet rest flat on the floor.
- Do not pull your chair forward or toward while operating the machine.



Using of Mask



Using waste boxes for collecting loose threads



Using of Needle Guard



Ensuring of Motor Pulley

- Use both hands to raise & lower the machine head.
- Always keep your head above the table.
- Keep your feet off the treadle when you are setting or threading the needle.
- Turn off and unplug your sewing machine when you are away from it for more than a few minutes.